

Knife Over Roll Coater

The choice for heavy and level coating to uneven surfaces



Knife Over Roll Coater



The Knife Over Roll Coater has traditionally been the choice when requiring to put down a very heavy and level coating of medium to high viscosity onto uneven surfaces such as textiles, fibre glass mats, non wovens. Typical applications include cast films, embossed and plain flooring, reinforced plastics, medical dressings, and textile adhesive coatings.

New technology has now been incorporated to improve the blade positioning and gap setting. This has resulted in repeatable blade positioning to an accuracy ± 2 microns, by the use of precision linear bearings and backlash-free ballscrews. This gap setting can be driven by servo motors and closed loop control from a coatweight monitor for optimum repeatability and control.

FEATURES

- Exceptionally strong, rugged construction to handle high hydrodynamic forces.
- High precision hard-chromed and ground backing roll manufactured to .4 RA finish and .002mm TIR as applicable.
- Profiled machined aluminium back and side dams to eliminate leakage.
- Gap setting based upon pneumatically loaded ground steel wedge system adjusted by back-lash free micrometer ball screws.
- Servo motor and encoder gap control to ensure the highest accuracy and repeatability.
- Closed loop control available linking servo drives to coatweight monitor for optimum process control and economy.
- Heated backing roll and blade where required.

SPECIFICATION

Viscosity range: 500–50,000 Cps

Web width range: 300–2500mm

Coatweight range: 25–2000 gsm wet

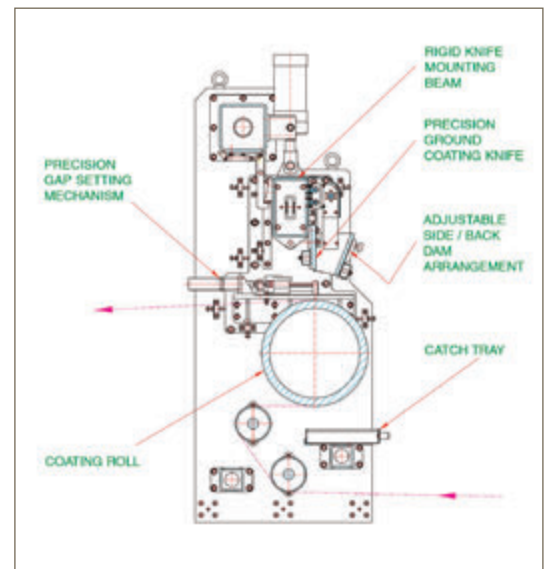

Delpro

Delpro Limited

Peakdale Road, Brookfield Industrial Estate, Glossop, Derbyshire SK13 6XE, UK
Tel: +44 (0)1457 862776 Fax: +44 (0)1457 862433 Email: sales@delpro.co.uk

www.delpro.co.uk